

CREST HD STAIRLIFT

“ I love my Crest HD Stairlift for the freedom & peace-of-mind it gives me! ”



LIMITED
LIFETIME
WARRANTY



CREST 710 STAIRLIFT



Features:

- Folds to within 12.5" of the wall
- Attaches to steps, not the wall
- Narrow, low profile track (2.5" tall x 6.5" wide)
- Footrest obstruction sensor with audio beep notification
- Battery power allows up to 20 trips during power outages
- Full length continuous charge system with smart charge technology
- Rocker switch conveniently located on either armrest
- Constant pressure controls
- Wireless remote controls for upper & lower landings
- Chassis mounted installation load switch
- Quickly installs on left or right side of stairway
- Rack and pinion drive with concealed gear rack
- High seat back
- Low-to-the-floor footrest
- 3" to 6" horizontal extension at top landing
- 25 to 45 degree angle applications
- ETL listed ASME A17.5 / B44 and A18.1
- 350 lbs capacity
- Overspeed governor
- Proudly made in the USA!



85 degree
swivel seat
at top landing

Technical Information

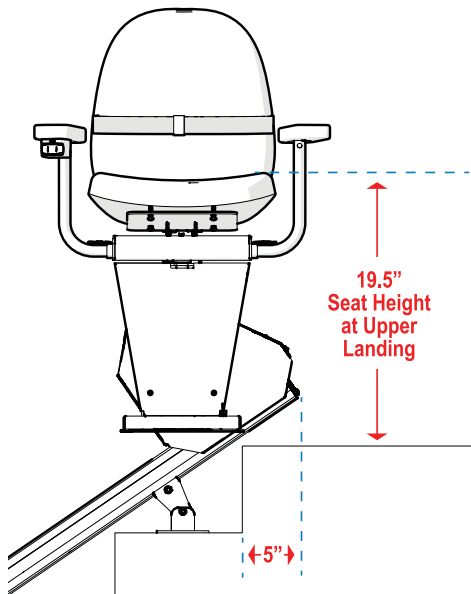
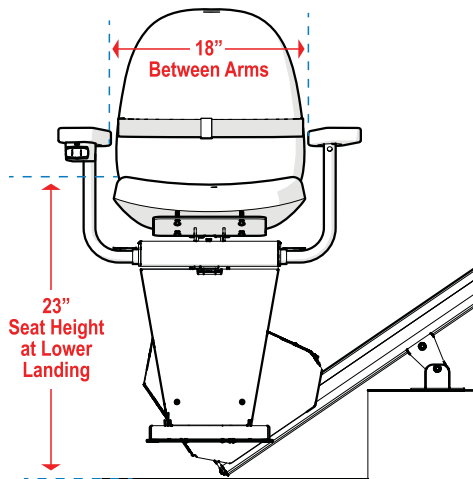
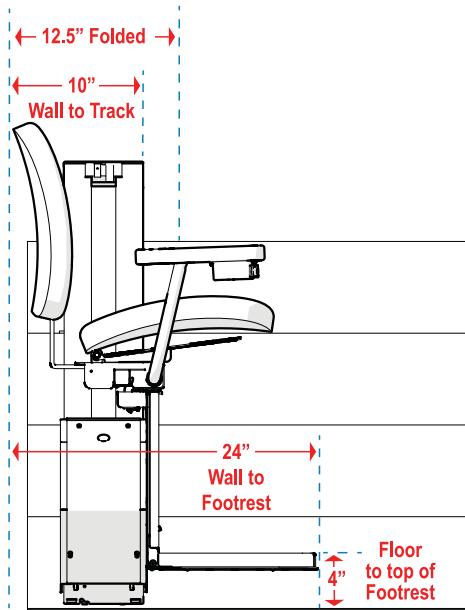

Dimensions subject to change without notice.

Staying Home Corporation • PO Box 37, Harrisonville, MO 64701
 info@stayinghome.com • 877-378-4275

09.13.19

Best Warranty In The Industry!

LIMITED LIFETIME WARRANTY

Lifetime to the original purchaser for:
 ALL PARTS OF THE LIFT
2 Year warranty on BATTERIES

Labor and Shipping of Warranty Parts
 are not covered in the warranty.

Outdoor package
 includes heavy duty cover



OUTDOOR WARRANTY

- 1 Year warranty on BATTERIES
- 2 Year warranty on PARTS
- 5 Year warranty on DRIVE TRAIN
 & CIRCUIT BOARD